



BIDS AND AWARDS COMMITTEE

Bid Bulletin No. 1 for 22nd Public Bidding CY2022

A. Supply and Delivery of Various Promotional Materials: T-shirts and Powerbanks

Technical Specifications:

Item 1. Powerbank

Specifications:

1. Qty: 900 units
2. Capacity: 20,000mAh
3. Connectivity: USB 3.0
4. Number of Ports: 2 ports with LED indicators
5. Battery Type: Lithium-ion Battery
6. Slim and fast-charging
7. With water-proof Sticker of the EVOSS Log
8. **Packaging: Individual Carton Box, Packaged in 50's carton Boxes**

Item 2. T-shirt with Collar & Placquet

Specifications:

1. Qty: 845 pcs
2. Sizes: XS, S, M, L, XL
3. Description: Lacoste type/pin Head Honeycombed Cotton
4. Print: Computerized embroidery
5. Color: 2 Colors
6. With Collar and Cuffs
7. **Packaging: Individual Plastic, Packaged in 50's carton Boxes**

B. Supply and Delivery of ICT Equipment: Twelve (12) Units of Desktop Computer and Fourteen (14) Units of Notebook/Tablet Computer

NONE

C. Supply and Delivery of ICT and Office Equipment: One (1) Unit of Desktop Computer, Two (2) Units of Laptop Computer, One (1) Unit of Interactive White Board, Heavy Duty Paper Shredder, Two (2) Units Voice Recorder, One (1) Unit of High-performance Document Scanner, One(1) unit of Document Scanner Automatic Feeder, One (1) Units of Portable Document Scanner and One (1) Lot Workstation

NONE



Republic of the Philippines
DEPARTMENT OF ENERGY
(Kagawaran ng Enerhiya)

D. Supply and Delivery of Various Furniture and Fixture: Two (2) Units Conference Table, Twelve (12) Units Conference Chair and Five (5) Sets of Work-Furniture

1. Correction: Title of Procurement under Item No. 2 of the Invitation to Bid should be: **“Supply and Delivery of Various Furniture and Fixture: Two (2) Units Conference Table, Twelve (12) Units Conference Chair and Five (5) Sets of Work-Furniture”**

2. Delivery Period:

The delivery period for this procurement is revised from thirty (30) Calendar Days upon receipt of Notice to Proceed to forty-five (45) Calendar Days upon receipt of Notice to Proceed.

3. Terms of Reference/Technical Specifications:

Attached is Annex A: Revised specifications indicating/illustrating the dimensions.

Considering the relaxation of restriction for COVID-19, the Opening of Bids can be witnessed personally or in case you have related constraint it could be witness through video conferencing via MS Teams platform. In preparation, you may download the app in advance to witness the proceedings. Bidders and observers may submit their intent to participate with the following information such as the nominated email address to bacsecretariat@doe.gov.ph

This Bid Bulletin forms part of the Terms of Reference. All other terms and conditions in the Bid Documents and other Bid Bulletin issued by the DOE-BAC not consistent with this Supplemental/Bid Bulletin shall remain valid and effective.

Approved for Issuance:

USEC. GIOVANNI CARLO J. BACORDO
Chairperson, Bids and Awards Committee

FGD/marc/jjad

Annex A: Revised Specification for the Procurement

Supply and Delivery of Various Furniture and Fixture: Two (2) Units Conference Table, Twelve (12) Units Conference Chair and Five (5) Sets of Work-Furniture Under Bid Bulletin No. 1 for the DOE 2nd Public Bidding

A. Technical Specification

1. Conference Table

Specifications (or equivalent):

- Approx. Dimension: 4000mm L x 1200mm D x 750mm H
- With rectangle wire cable grommet
- Laminated Wood
- Melamine Face Chipboard (MCF)
- Powder coated Point Frame with Glides
- Color: Shade of Gray

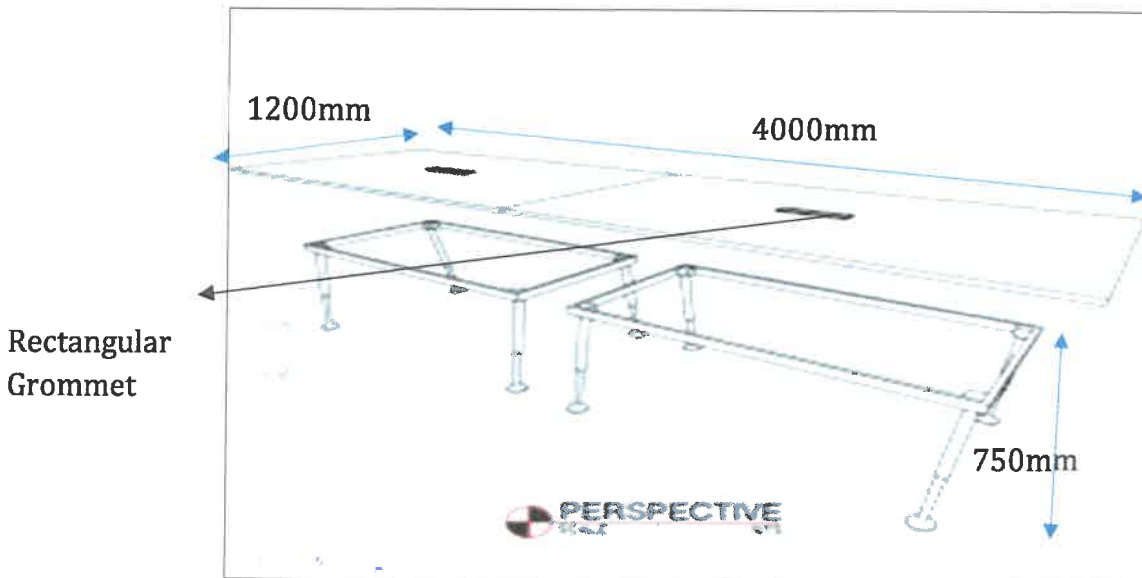

2. Conference Chair



Specifications (or equivalent):

- High back with Armrest
- Leatherette Upholstered Seat rest and Backrest
- 360 Swivel; Tension Control
- Pneumatic Height Adjustment, Tilt Lock Mechanism
- Chrome Plated Base
- Color: Black
- Wheels: Five (5) Heavy Duty Caster Wheels
- Weight Capacity: At least 100 kg
- Approx. Height: 120 cm x Width 60 cm

3.1 Furniture Set – Set 1 (Lab 1 – KS/Software) : Quantity – 1 Set

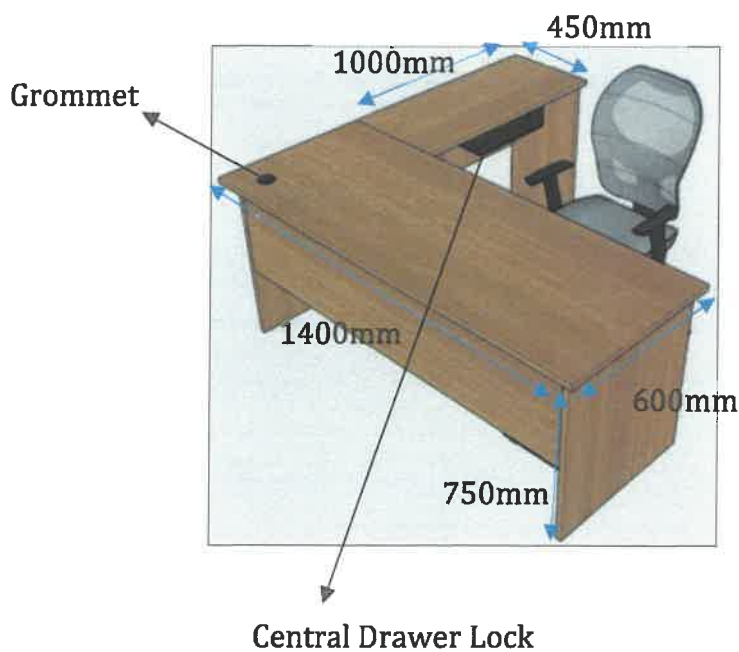

Specifications (or equivalent):

- **Freestanding Main Table**
 - MFC Laminated
 - Wood Grain Color
 - With 1pc Grommet
 - Approx. Dim: W1400 x D600 x H750 mm
- **Side Return Table**
 - MFC Laminated
 - Wood Grain Color
 - With 1pc Grommet
 - Approx. Dim: W1000 x D450 x H660 mm
- **Central Drawer with Lock**
 - Powder-coated Steel Finish
 - Approx. Dim: W400 x D480 mm
 - Color: Black
- **High Back Executive Chair**
 - Mesh Black / Fabric Seat
 - Height Adjustable PU Armrest
 - Lumbar Support
 - Tilting Mechanism
 - At least: W620 x D525 x H985 mm

3.2 Furniture Set – Set 2 (Guard Reception Counter) : Quantity – 1 Set

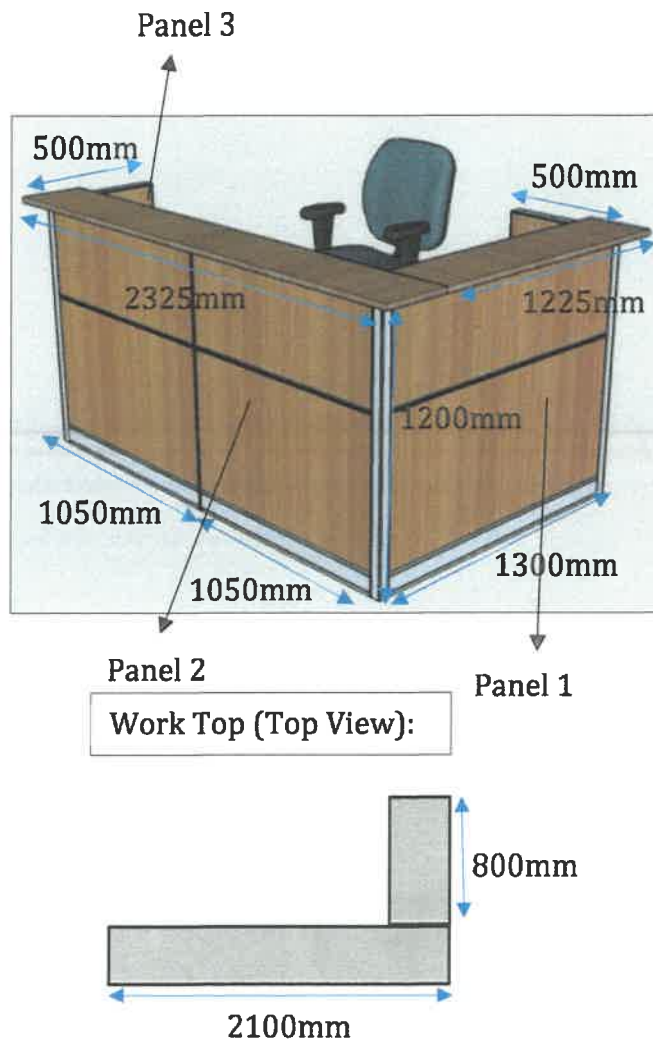

Specifications (or equivalent):

- Laminated Partitions
 - MFC Laminated
 - One (1) Dim: H1200 x W1300mm
 - Two (2) Dim: H1200 x W1050mm
 - Two (2) Dim: H1200 x W500 mm
 - Wood Grain Color
 - Silver Aluminum Trimmings
 - Baseboard Raceway
 - Thickness: 50 mm
- Work Top
 - MFC Laminated
 - One (1) Dim: W2100 x D500 mm
 - One (1) Dim: W800 x D500 mm

- Grommet
- Wood Grain Color
- Thickness: 25 mm
- Counter Top
 - MFC Laminated
 - One (1) Dim: W2325 x D300 mm
 - One (1) Dim: W1225 x D300 mm
 - Grommet
 - Wood Grain Color
 - Thickness: 25 mm



- Low Back Stool Chair with Foot ring
 - Leatherette with upholstered back and seat
 - Fixed Armrest
 - 5-Star Polypropylene Base
 - Gas lift
 - At least: W460 x D590 x H1040 mm

3.3 Furniture Set – Set 3 (EA OD) : Quantity – 1 Set

Specifications (or equivalent):

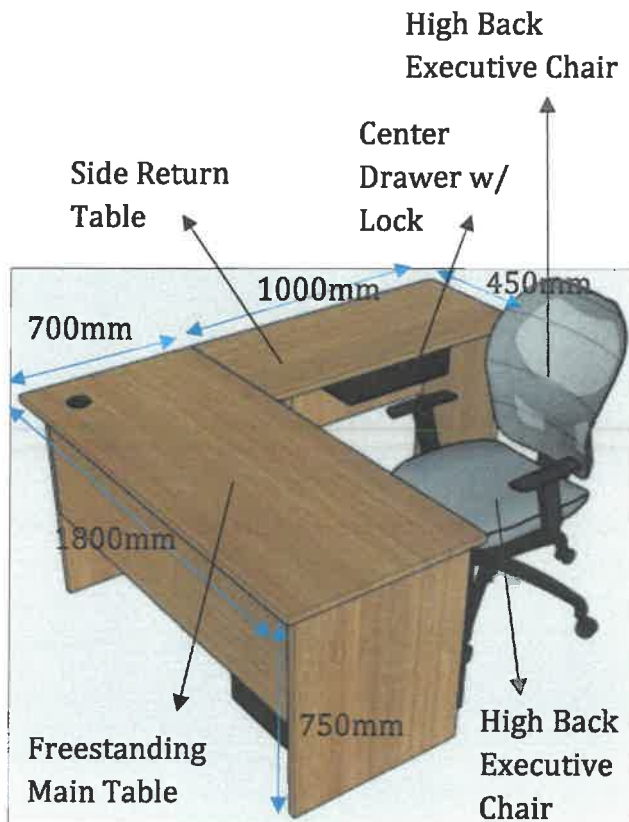

- **Freestanding Main Table**
 - MFC Laminated
 - Wood Grain Color
 - Approx. Dim: W1800 x D700 x H750 mm
- **Side Return Table**
 - MFC Laminated
 - Wood Grain Color
 - Approx. Dim: W1000 x D450 x H750 mm
- **Center Drawer with Lock**
 - Powder coated finish
 - Color: Black
 - Approx. Dim: W400 x D480 mm
- **High Back Executive Chair**
 - Mesh Black / Fabric Seat
 - Height Adjustable PU Armrest
 - Lumbar Support
 - Tilting Mechanism
 - At least: W620 x D525 x H985 mm
 -

3.4 Furniture Set – Set 4 (Working Station) : Quantity – 4 Set

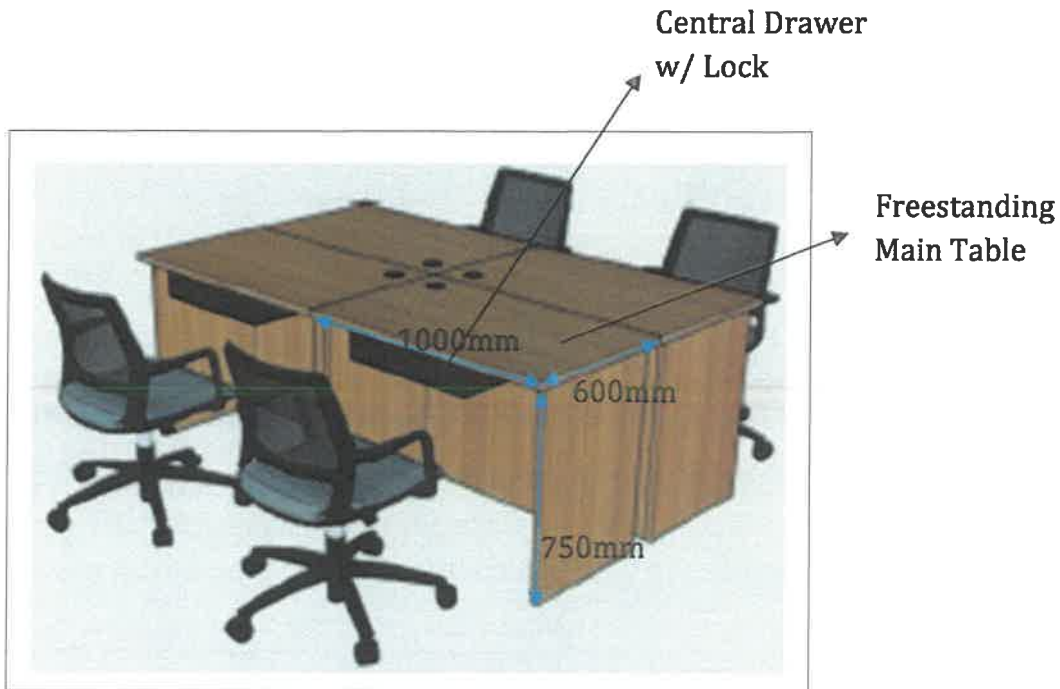

Specifications (or equivalent):

- Freestanding Main Table (4 Units)
 - MFC Laminated
 - Wood Grain Color
 - With 1 pc. Grommet
 - Approx Dim: W1000 x D600 x H750 mm
- Central Drawer with Lock (4 Units)
 - Powder-coated Steel Finish
 - Approx Dim: W400 x D480 mm
 - Color: Black
- Mid Back Task Chair (4 Units)
 - Mesh Black / Fabric Seat
 - Leatherette Seats
 - Armrests
 - No tilt Mechanism
 - Black
 - At least: W560 x D620 x H860 mm

3.5 Furniture Set – Set 5

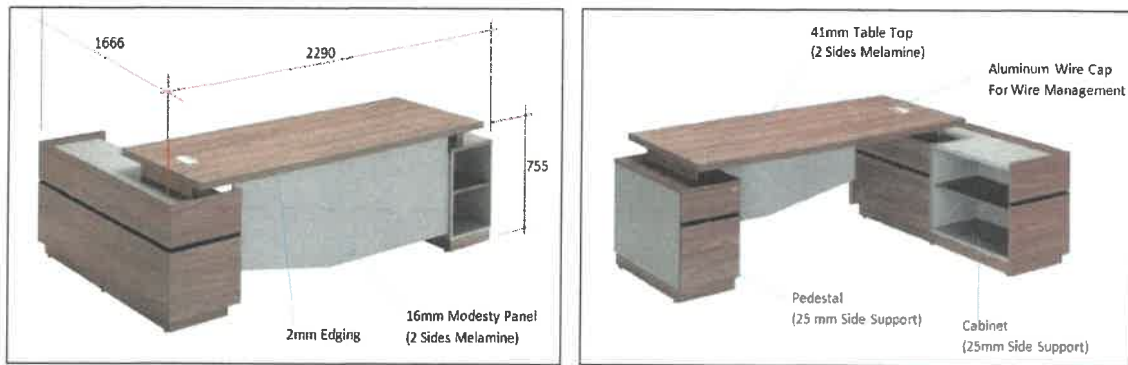

**High Back
Executive
Chair**

Specifications (or equivalent):

- **Executive Table**
 - Approx. Dim: W2290 x D1666 x H755mm
 - Table Top: 41 mm; 2 sides melamine
 - Pedestal and Cabinet Top: 25 mm
 - Side Support and Modesty Panel: 16mm 2 sides melamine
 - Aluminum wire cap
- **High Back Executive Chair**
 - Modern Design
 - PVC Leatherette Upholstery
 - Armrests
 - Aluminum Base
 - Self-Weight Synchro Mechanism
 - Approx. Dim: W660 x D685 x H1250 mm